

4

3

DWG NO. DOC-903000-1 SH REV 2

1

REVISIONS			
REV	DESCRIPTION	DATE	APPROVED

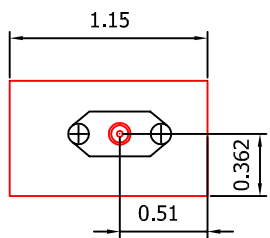
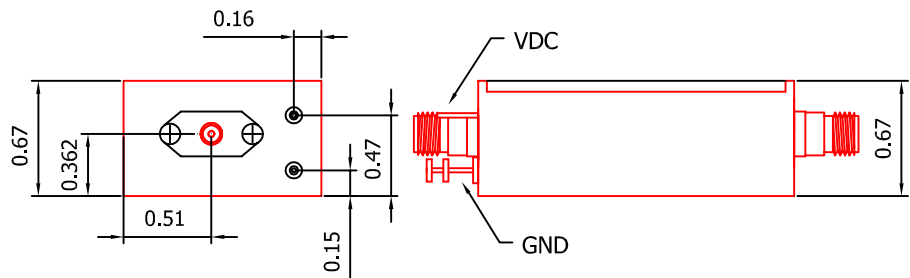
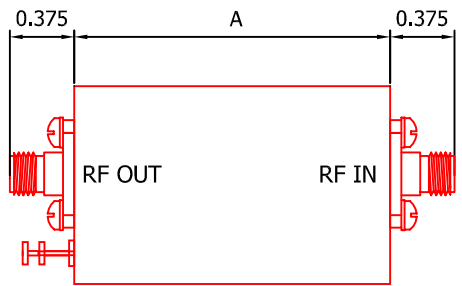

CASE	"A" DIM	"B" DIM	"C" DIM
3	1.087	0.500	0.375
4	1.337	0.750	0.375
5	1.587	1.000	0.375
51	1.750	1.125	0.375
6	1.837	1.250	0.418
61	1.837	1.250	0.375
7	2.087	1.500	0.375

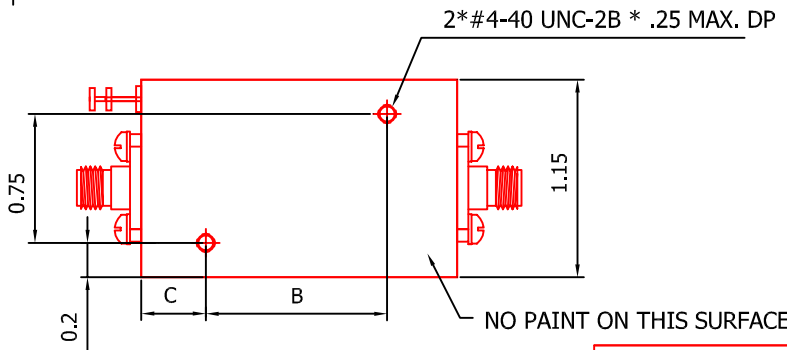

UNLESS OTHERWISE SPECIFIED: DIMENSIONS ARE IN INCHES TOLERANCES		CONTRACT NO.		<b>TRANSCOM, INC.</b>	
DECIMALS	ANGULAR	DRAWN	DATE		
.XX ± .02	±	宋君麟	05/23/2005	TITLE <b>HOUSING OUTLINE          HC</b>	
.XXX ± .010		張景學	05/23/2005		
FINISH		PROJ ENGR		SIZE	FSCM NO.
DO NOT SCALE DRAWING		MFG ENGR		DWG NO.	DOC-903000-1
MATERIAL	AL	QA ENGR		SCALE	WEIGHT
UNLESS OTHERWISE SPECIFIED BY CONTRACT THESE DRAWINGS AND SPECIFICATIONS AND DATA DISCLOSED HEREIN ARE THE PROPERTY OF TRANSCOM, INC. ISSUED IN STRICT CONFIDENCE AND SHALL NOT BE REPRODUCED OR DISCLOSED IN WHOLE OR PART OR USED AS THE BASIS FOR MANUFACTURE OR SALE WITHOUT THE PERMISSION OF TRANSCOM.		RLSE DATE		SHEET	1 OF 1
				REV	2

4

3

2

1